

Dyna-Feed

Vibratory Bowl Bulk Supply Solutions

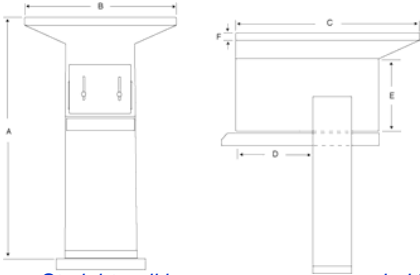

Straight Wall Hopper

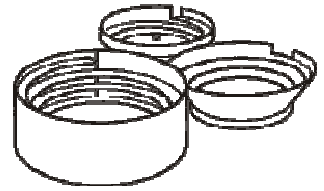

Straight wall hopper are recommended for parts exceeding 1.5 cu in (approx 3" Length) or parts that tend to bridge or tangle

Hopper Capacity	A Discharge Height	B Overall Width	C Overall Length	D Pan Extension	Hopper L x W	Hopper Straight Wall	Base L x W
1/4 cubic foot	16.50"	8.25"	10.25"	3.25"	10.25 x 8.25	0	3.25 x 10
1/2 cubic foot	23"	8.25"	10.25"	9"	10.25 x 8.25	6.5"	3.25 x 10
2 cubic foot	31"	22.5"	30.25"	26 3/8 or 29 3/8	17.5" x 11.25"	2"	6 x 14.5
3 cubic foot	34"	22.5"	30.25"	26 3/8 or 29 3/8	17.5" x 11.25"	3"	6 x 14.5
5 cubic foot	40"	36.25"	39.50"	26 3/8 or 29 3/8	17.5" x 11.25"	9"	6 x 14.5
10 cubic foot	47"	36.25"	47"	26 3/8 or 29 3/8	17.5" x 11.25"	12"	6 x 14.5

Other capacities available. Gravity Hoppers are also available.



Tapered Wall Hopper

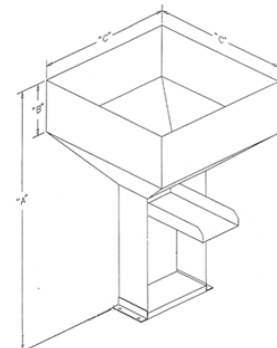

Hopper Capacity	A Overall Height	B Bin Height	C Pan Extension	D Overall Pan Height	Hopper L x W	Pan Length X Width	Base L x W
3 cubic foot	35.75	6"	24.25" x 24.25"	20"	22 x 22	9" x 7.25"	6" x 14.5"
5 cubic foot	41.75"	12"	24.25" x 24.25"	20"	22 x 22	9" x 7.25"	6" x 14.5"
7 cubic foot	42"	7.25"	36.25" x 36.25"	20"	22 x 22	9" x 7.25"	6" x 14.5"
10 cubic foot	46.5"	12"	36.25" x 36.25"	20"	22 x 22	9" x 7.25"	6" x 14.5"

Available in both Painted 11 Ga HRS and 304 SS. Lined Hopper are also available for "gentle handling applications. Low Profile and Large Capacity w/ Discharge Pan and Low Profile Elevator Feeder Styles are also available.

CDS LIPE * 7650 Edgecomb Drive * Liverpool, N.Y. 13088 * 800-448-7822

Dyna-Feed

Vibratory Bowl Bulk Supply Solutions



PEDISTAL HOPPER

Features heavy duty taper wall hopper complete w/ speed and level control sensor. Flow Control Gate. Heavy Part Capacity, Lined & Unlined, Painted Mild Steel Construction
 1 cu ft Low Profile
 1 cu ft Expander
 2cu ft Expander
 5 cu ft Expander
 Fixed & Portable Machine Base

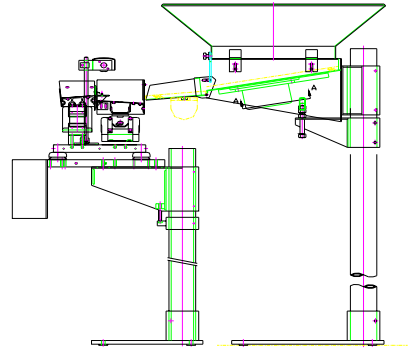

TOTE UNLOADER

Features heavy duty vibratory frame complete w/ speed and level control sensor. Handles Front Unload Tote Heavy Part Capacity, Painted Mild Steel Construction

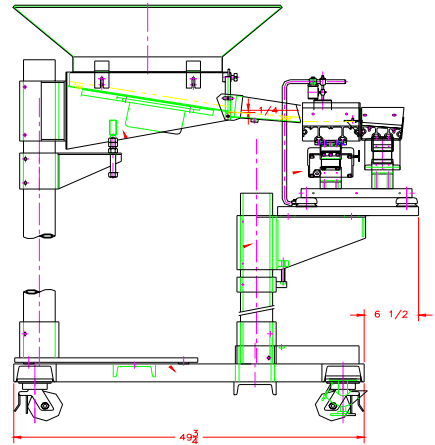

METERING PAN-FEEDER/HOPPER-TRICKLE BELT FEEDER

Features pan or chute comprised of linear drive sized to .5 cu ft to 5 cu.ft. supply capacity. Mild Steel, 304ss and 316 ss Construction.



Dyna-Feed Product Line includes:

- Bulk Supply Hoppers:
- Linear Metering Pans
- Low Level Elevator-Feeders
- Drives:
- Vibrator Frequency Controllers:
- Lined Bowls:
- Linear Feeder:
- Discharge Tracks, Rails, Conveyors:
- Sound Enclosures
- Escapements & Pick & Place Modules:
- Pick & Place Devices:
- Machine Bases & Stands:
- Specialty Vibratory Feeder Based Machines:

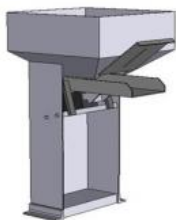

Quality	Flexibility
Experience	Innovation

CDS LIPE * 7650 Edgecomb Drive * Liverpool, N.Y. 13088 * 800-448-7822